

A-107

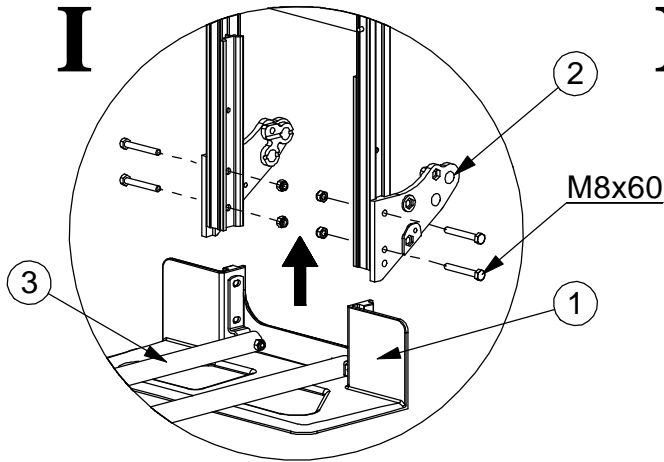

Please follow → direction for assemble.

- ① nose plate
- ② axle boxes
- ③ extension nose plate then tight them.

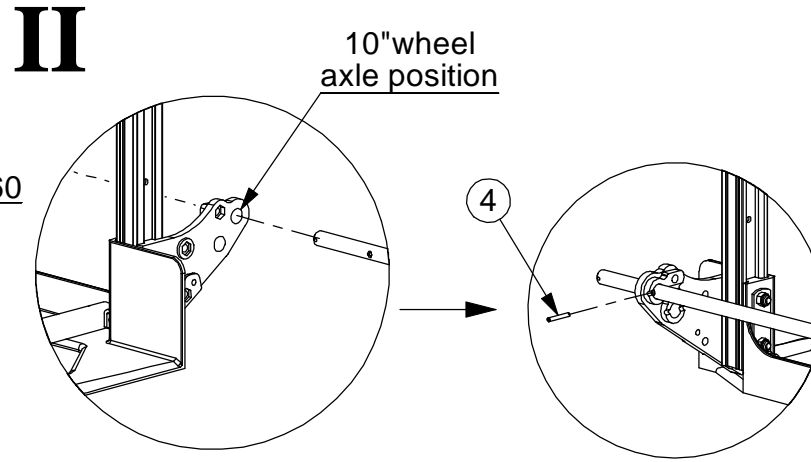

Assemble the axle

insert ④ spring pins.

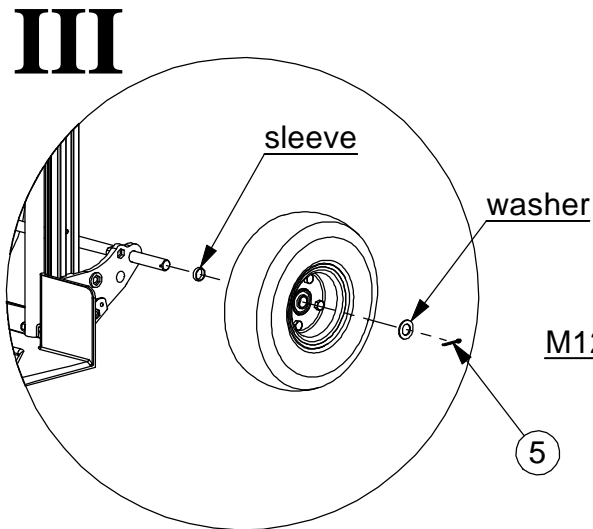

Insert sleeve washer, wheels in each side, and put the ⑤ cotter pins. Please bend the cotter pins.

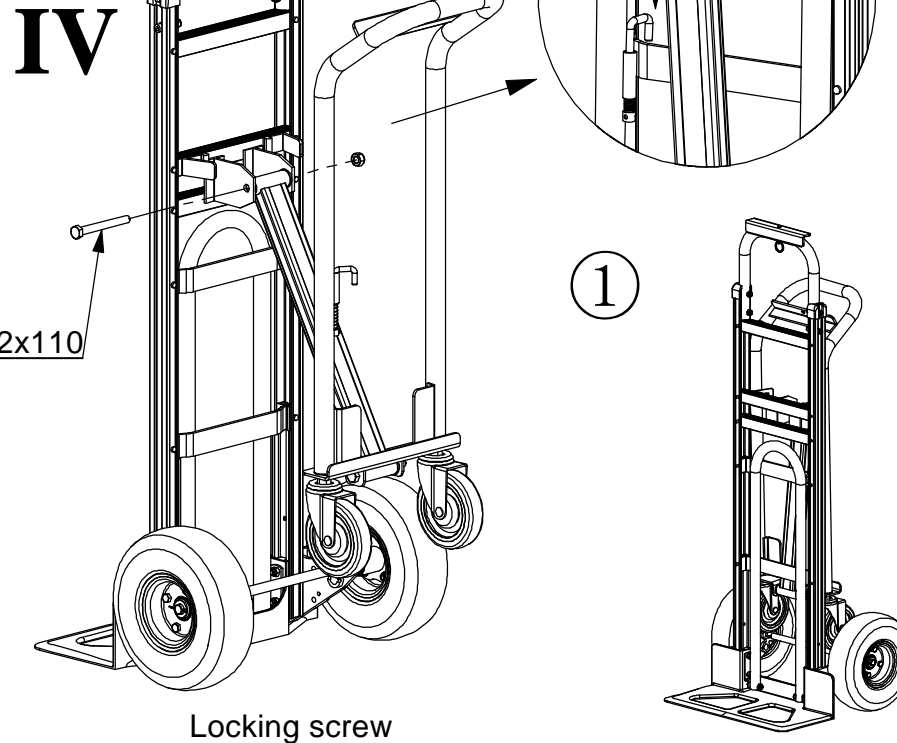

Locking screw

- ※ Read instructions thoroughly before proceeding.
- ※ Tighten all parts by hands. Don't use power tool.
- ※ For your safety, please do not overload.
- ※ For pneumatic wheel: Please check air pressure in tires. Maintain (30) PSI.

